

Kingdom of Saudi Arabia
Ministry of Health



National eHealth Strategy and Change Management Office
(SCMO)

Enabling Standards-Based eHealth Interoperability

UC0005

Saudi eHealth Imaging Interoperability Use Case

Version 1.0
February 22, 2015

Document Control Number: UC0005 Saudi eHealth Imaging Interoperability Use Case

THIS PAGE INTENTIONALLY LEFT BLANK

TABLE OF CONTENTS

CONFIDENTIALITY STATEMENT:	6
DOCUMENT REVISION HISTORY	6
PREFACE	7
KEY CONCEPTS	7
APPROACH.....	8
CONVENTIONS	9
Process Flow Diagrams	9
Requirements Language	10
PROJECT PURPOSE.....	11
REFERENCES	12
National eHealth Strategy.....	12
Saudi eHealth Interoperability Specification Document	12
Saudi Health Information Exchange Policy Document.....	12
MIDDLE- OUT METHODOLOGY	13
IMAGING BASED INTEROPERABILITY USE CASES	16
1. SHARING IMAGES AND IMAGING REPORTS - INTEROPERABILITY USE CASE	16
1.1 Description	16
1.2 Use Case Benefits	16
1.3 Actors	16
1.4 Main Flow of Events.....	18
1.5 Alternative Flow of Events	19
1.5.1 Image Sharing With Notification of Document Availability Flow	19
1.5.2 Amended Report Flow	20
1.6 Exceptions Work Flow	22
1.7 Specific Workflow Scenarios	22
1.7.1 Scenario 1: Basic –Pre-fetching For a New Radiology Order	22
1.7.2 Scenario 2: Ad Hoc or On-Demand Image Fetch From Imaging Repository... ..	22
1.7.3 Scenario 3: Pre-Fetch Of Relevant Priors from Imaging Repository Into Local Hospital Initiated By Patient Visit (non-radiology workflow).....	22
1.7.4 Scenario 4: Report-Only Prior Retrieval.....	22
1.7.5 Scenario 5: Report is amended after pre-fetch has occurred to local system ...	23
1.7.6 Scenario 6: Images are added/changed after pre-fetch has occurred to local system.....	23
1.7.7 Scenario 7: Emergency patient comes in and is imaged at local site.....	23
1.7.8 Scenario 8: An Identified Emergency Patient Comes In and Is Imaged But Not Yet Reported, When The Patient Needs To Be Transferred To Another Site....	23
1.7.9 Scenario 9: An unidentified emergency patient comes in and is imaged but not yet reported, when the patient needs to be transferred to another site	24
1.7.10 Scenario 10: Split Imaging Procedures	24

1.8	Service Model	24
1.9	Service Description	25
1.10	Pre-Conditions	25
1.11	Post-Conditions.....	26
1.12	Data Requirements	26
1.12.1	Image Report Data	26
1.12.2	Image Manifest Data.....	28
1.13	Assumptions and Dependencies.....	28
1.14	Special Requirements.....	29
1.15	Notes and Issues.....	29
1.15.1	Three Configurations Using Saudi National Imaging Repository	29
2.	TELE-RADIOLOGY ORDER – INTEROPERABILITY USE CASE.....	32
2.1	Description	32
2.2	Use Case Benefits	32
2.3	Actors	32
2.4	Main flow of Events.....	33
2.5	Exceptions Work Flow	35
2.5.1	Order Canceled	35
2.6	Specific Workflow Scenarios	37
2.6.1	Tele-Radiology Order Transition State Diagram	37
2.6.2	Scenario 1: Tele-radiology service processes a successful order	38
2.6.3	Scenario 2: A Tele-Radiology Order Is Cancelled Before It Has Been Processed By the Tele-Radiology Service	38
2.6.4	Scenario 3: A Tele-Radiology Order Is Processed By the Tele-Radiology Service and Is Aborted	38
2.6.5	Scenario 4: A Tele-Radiology Order Is Cancelled but It Has Already Been Processed By the Tele-Radiology Service	39
2.7	Service Model	39
2.8	Service Description	40
2.9	Pre-Conditions	40
2.10	Post-Conditions.....	40
2.11	Data Requirements	41
2.11.1	Tele-Radiology Order Data	41
2.12	Assumptions and Dependencies.....	41
2.13	Special Requirements.....	42
2.14	Notes and Issues.....	42

LIST OF TABLES

TABLE 1.1 SEHE BUSINESS PROCESS MODELING NOTATION CONVENTIONS	9
TABLE 1.2 1 ACTORS.....	17
TABLE 1.2 2 SERVICES.....	25

TABLE 1.2 3 PRE-CONDITIONS	25
TABLE 1.2 4 POST CONDITIONS	26
TABLE 1.2 5 DISPLAYABLE RADIOLOGY REPORT DATA CONTENT	27
TABLE 1.2 6 BASIC STRUCTURED RADIOLOGY REPORT DATA CONTENT	27
TABLE 1.2 7 IMAGE MANIFEST DATA CONTENT	28
TABLE 1.2 8 USE CASE DEPENDENCIES	28
TABLE 1.3 1 ACTORS	33
TABLE 1.3 2 SERVICES	40
TABLE 1.3 3 PRE-CONDITIONS	40
TABLE 1.3 4 POST CONDITIONS	40
TABLE 1.3 5 TELE-RADIOLOGY ORDER DATA CONTENT	41
TABLE 1.3 6 USE CASE DEPENDENCIES	41

LIST OF FIGURES

FIGURE 1.1-1 SCOPE OF EHEALTH STANDARD BASED INTEROPERABILITY SPECIFICATIONS AND POLICY PROJECT	12
FIGURE 1.1-2 METHODOLOGY STEPS FOR THE EHEALTH STANDARDS-BASED INTEROPERABILITY SPECIFICATIONS AND POLICY PROJECT	13
FIGURE 1.1.3 VERIFICATION OF CONFORMANCE TO A CORE SAUDI EHEALTH INTEROPERABILITY SPECIFICATION	15
FIGURE 1.2 1 SHARING IMAGES AND IMAGING REPORTS MAIN PROCESS FLOW ALTERNATIVE FLOW OF EVENTS	19
FIGURE 1.2 2 SHARING IMAGES AND IMAGING REPORTS WORKFLOW WITH NOTIFICATION OF DOCUMENT AVAILABILITY	20
FIGURE 1.2 3 REPORT AMENDMENT TYPICAL PROCESS FLOW	21
FIGURE 1.2 4 SHARING IMAGES AND IMAGING REPORTS SERVICE MODEL	24
FIGURE 1.2 5 CONFIGURATIONS USING IMAGING REPOSITORY	29
FIGURE 1.3 1 TELE-RADIOLOGY ORDER TYPICAL FLOW	35
FIGURE 1.3 2 TELE-RADIOLOGY CANCEL ORDER	37
FIGURE 1.3 3 TELE-RADIOLOGY ORDER TRANSITION STATE DIAGRAM	38
FIGURE 1.3 4 TELE-RADIOLOGY ORDER SERVICE MODEL	39

Confidentiality Statement:

The Ministry of Health (MOH) of the Kingdom of Saudi Arabia grants to any user of this document, perpetual, royalty-free, nontransferable, nonexclusive, license under its copyrights to access and read the Saudi eHealth Specification. You may not reproduce or use this document or any portion of it, without prior written consent from the MOH. The licenses covered are only to those parts owned or controlled by the MOH itself. If parts of the Saudi eHealth Specification include materials owned or controlled by other parties, licenses to use those products would have to be obtained from that other party.

The MOH offers the licensed material as-is and as-available, and makes no representations or warranties of any kind concerning the licensed material, whether express, implied, statutory, or other. This includes, without limitation, warranties of title, merchantability, fitness for a particular purpose, non-infringement, absence of latent or other defects, accuracy, or the presence or absence of errors, whether or not known or discoverable. To the extent possible, in no event will the authors and licensor be liable on any legal theory (including, without limitation, negligence) or otherwise for any direct, special, indirect, incidental, consequential, punitive, exemplary, or other losses, costs, expenses, or damages arising out of this public license or use of the licensed material, even if the licensor has been advised of the possibility of such losses, costs, expenses, or damages.

Document Revision History

VERSION	DATE	TYPE OF UPDATE	PREPARED/REVISED BY
1.0	February 22, 2015	First Release	eHealth Strategy Management Office – eHealth Standards Department

PREFACE

KEY CONCEPTS

Key concepts used in this document are introduced below. Consult *ISO302 SeHE Project Glossary* for other terms used within this document.

Interoperability Use Case: In software engineering, a Use Case is a technique for capturing the requirements of a new or updated system. Each Use Case provides one or more business scenarios that convey how the system should interact with end-users or other systems to achieve a specific business goal. Interoperability Use Cases use language that end-users and domain experts can understand, rather than technical jargon. Use Cases are often co-authored or co-developed by business analysts and end-users.

Business Scenario: The business scenario is defined as a sequence of activities by one or more users (e.g. patients, clinicians, etc.) that describe a real-world story. A business scenario executes one or more business processes in a sequence of end-user interactions called a process flow. Business scenarios are the starting point of the analysis leading to the discovery of actors and services necessary to meet the requirements of the assigned Use Case.

Actors: In this specification actors describe the interoperable software components which support interoperable exchanges of information between systems.

Services: Services describe collections of capabilities of a system that enable communication and exchange through standards-based messages and information content. A capability within a service describes the smallest unit of useful work that facilitates information exchange between systems.

Process Flow: A process flow represents a possible sequence of business processes being executed to perform the work of the Use Case. Process flows are identified by analysis of business scenarios through the identification of common reusable sequences of business processes.

Main Flow: The main flow of a Use Case usually describes the simplest path through the smallest set of business processes necessary to complete the work of the Use Case. It describes the minimal skeleton of the Use Case which appears in common across the various business scenarios which explore the scope of the Use Case. The main flow is the sequence of business processes that is both common to and required to be executed in all normal business scenarios.

Alternative Flow: Alternative flows describe additional paths that can be taken to provide additional capabilities to the main flow of work. Alternative flows are described as auxiliary paths that can be added-on to the main flow in one or more locations.

Exception Flow: Exception flows describe alterations to the main flow under exceptional or out of the ordinary circumstances. The existence of exception flows allows for alternative exit paths from the main flow that allow a work flow to complete under extreme situations, even though it deviates from the main flow.

Business Process: A business process is a reusable unit of interaction between an end-user and one or more information systems. Business processes perform work through the execution of services provided in the information system environment.

APPROACH

The approach used to develop this Use Case specification starts with the identification of a stakeholder group of end-users, beneficiaries and implementers of systems which may be affected by implementation of Interoperability Specifications supporting the Use Cases in the work stream described by this document. These stakeholders identify real-world scenarios in which users and other individuals (e.g., patients) interact with systems to perform or receive a service. The process used is as follows:

- Scenarios are identified by first identifying the simplest (but not necessarily the most common) case in which the Use Case can be completed. More complex scenarios are added which illustrate the range of complexity of the Use Case until essential requirements have been identified.
- Through analysis of these scenarios, a main flow, and often one or more alternative and exception flows are identified. These process flows identified need not match one-to-one with the real-world scenarios originally used to explore the Use Case; however, they are derived from them.
- The process flows are decomposed into business processes, where a business process is described as an end-user initiated interaction with one or more systems in order to complete some essential task in the Use Case.
- The systems and business processes are analyzed to identify the common system components (Actors) responsible for supporting the end-user in the work being done.
- The actors and business processes are further analyzed to identify the necessary services which support the requirements identified in the Use Case.
- The collection of actors and services forms the solution space for the Use Case, representing the system components and the interoperability that is necessary to meet the requirements of the Use Case.
- From business scenarios implemented by systems and operated by users to actors and services, the derivation of the service model can be shown through a clear progress of analysis.

Lastly, stakeholders contribute candidate data elements to the use case that support the information exchanges identified in the business scenarios.

CONVENTIONS





This document has adopted the following conventions for representing the Use Case concepts and information workflow.



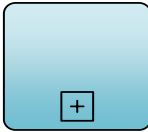

Process Flow Diagrams

The descriptions of interoperability Use Cases that follow include process flow diagrams that illustrate a series of visual representation of related tasks that a person, business, and/or system executes to achieve a desired outcome of the Use Case. The process flow diagrams are created using the Business Process Modeling Notation (BPMN) format. The notations of the diagram represent different shape such as an event (a circle shape denotes start/end of process), an activity (a rectangle describes actions performed by the actor), a gateway (diamond shape determines forking and merging of paths depending on the conditions expressed), and a connector to show in which order the activities are performed and the intermingling of actions between actors and other systems. Complete explanations of the business process diagram elements used within this document are in the table below.

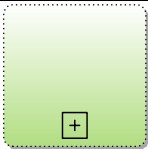
There are main process flows, followed by optional alternative or exception flows.

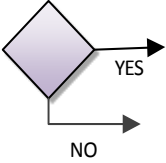
Table 1.1 SeHE Business Process Modeling Notation Conventions

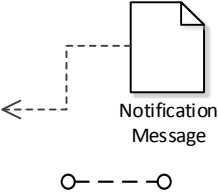
SHAPE	DESCRIPTION
	Start event acts as a trigger to launch the business process.
	End event acts as a trigger to terminate the business process.
	Activity that represented with a rounded-corner rectangle and describes systematic action performed by the actor
	Sub-process used to denote additional levels of business process by referring to an action that can be broken down to a finer level of details or to another business process name.
	External activity that represented with a rounded-corner rectangle and describes systematic action performed by the actor
	External sub-process used to denote additional levels of business process by referring to an action that can be broken down to a finer level of details or to another business process name.

SHAPE	DESCRIPTION
	Activity that represented with a light colored rectangle and describes physical action performed by the actor
	Gateway that determines forking and merging of paths depending on the conditions expressed
	Sequence flow that shows in which order the activities are performed and the intermingling of actions between different actors or other systems.
	Message flow that shows the flow of messages between two actors or systems that are prepared to send and receive messages.
Send Notification 	Message event used to send a message and to invoke other activity within the business processes then the token will immediately moves to the invoked flow of the process

Requirements Language

Throughout this document the following conventions¹ are used to specify requirement levels:

SHALL: the definition is an absolute requirement of the specification.

SHALL NOT: the definition is an absolute prohibition of the specification.

SHOULD: there may exist valid reasons in particular circumstances to ignore a particular item, but the full implications must be understood and carefully weighed before choosing a different course.

SHOULD NOT: there may exist valid reasons in particular circumstances when the particular behavior is acceptable or even useful, but the full implications should be understood and the case carefully weighed before implementing any behavior described with this label.

MAY or OPTIONAL: means that an item is truly optional. One vendor may choose to include the item because a particular marketplace requires it or because the vendor feels that it enhances the product while another vendor may omit the same item.

¹ Definitions based upon RFC 2119

PROJECT PURPOSE

The National eHealth strategy has established a number of key business objectives for the Saudi eHealth program including the definition and implementation of healthcare applications to support critical business scenarios.

Within this overarching strategy, an eHealth Standards-based Interoperability Specification and Policy project has been identified, with scope defined to:

- Deliver the Interoperability Specifications (i.e. standards, profiles, terminologies, etc.)
- Deliver test plans, test tools, and testing and certification policies to support the associated conformance testing for new and existing information systems (Hospital Information Systems [HIS], Primary Healthcare [PHC] Systems, Electronic Medical Record [EMR] Systems, Laboratory Information Systems [LIS], Radiology Information Systems [RIS]/ Picture and Archiving Communication Systems [PACS], etc.). These test plans, test tools, and testing and certification policies will ensure that these systems connect to the a Saudi Health Information Exchange (HIE) platform and its internal Systems which includes patient identification management, provider directory, document and image repository, and access control, etc.
- Establish the policies for health information exchange in Saudi Arabia. These policies ensure trust relationships between the various healthcare organizations sharing information as well as the health professionals and patients in the Kingdom.

The project's goal is to enable interoperability and to mainly specify the external interfaces of the local edge systems (i.e. point of care HIS or PHC applications), without constraining:

- The local systems' internal design
- The intra-organization interoperability policies or management processes used to implement such polices.

Figure 1.1-1 Scope of eHealth Standard based Interoperability Specifications and Policy Project depicts the general scope and focus of the project highlighted in red.

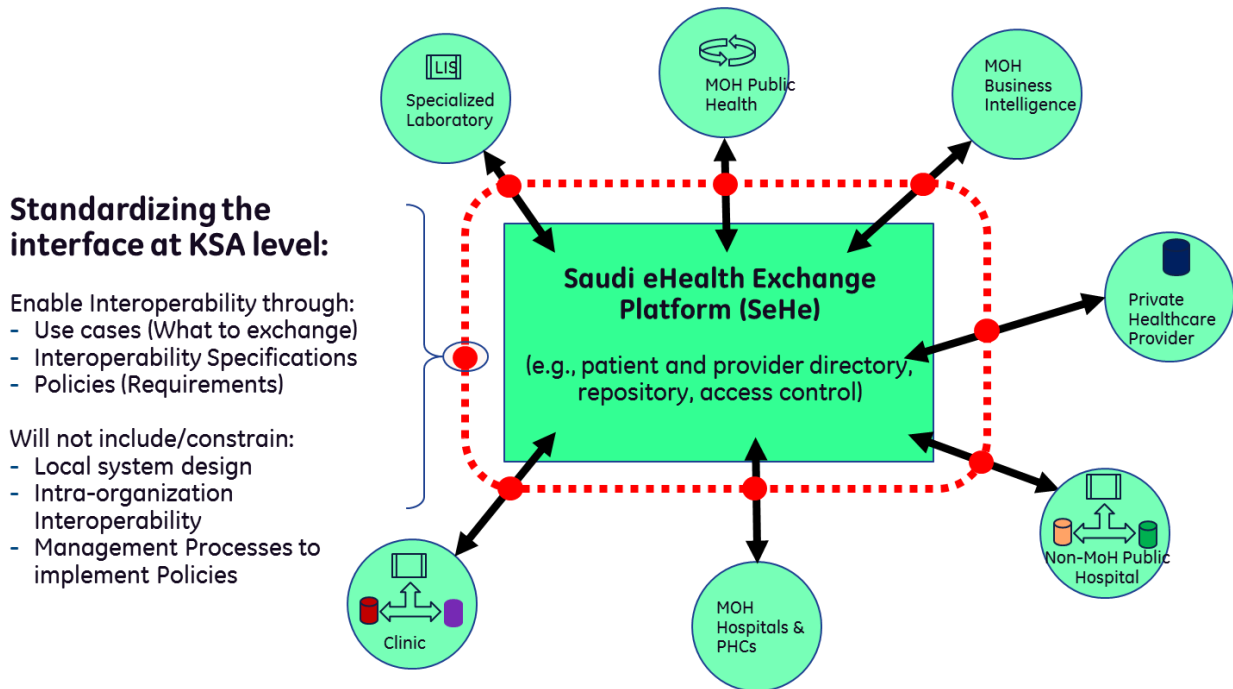

Figure 1.1-1 Scope of eHealth Standard based Interoperability Specifications and Policy Project

REFERENCES

National eHealth Strategy

See the Saudi Ministry of Health Portal (Arabic:

<http://www.moh.gov.sa/Ministry/nehs/Pages/default.aspx> English:

<http://www.moh.gov.sa/en/Ministry/nehs/Pages/default.aspx>) for more information.

Saudi eHealth Interoperability Specification Document

A Saudi eHealth Interoperability Specification documents the selection of profiles and standards that support specific Saudi eHealth Interoperability Use Cases. Such Interoperability Specifications apply to new and existing information systems (HIS, PHC, Laboratory, etc.) and ensure their connection to the national Saudi Health Information Exchange platform (HIE).

Saudi Health Information Exchange Policy Document

IS0303 *Saudi Health Information Exchange Policies* is used to set the policies applicable to users and systems connected to the HIE Platform.

Examples of such policies are:

- Authentication Policy
- Consent and Access Control Policy
- Identity Management Policy
- Breach Notification Policy

- Others

The Use Cases specified in this document operate within the context of these Health Information Exchange policies.

MIDDLE- OUT METHODOLOGY

Like most eHealth programs around the world, the challenge to identify and document a large number of business Use Cases and variants is avoided by using a “middle-out” methodology. The core requirements start with the Interoperability Use Cases, especially when those are “classical Use Cases” that have been analyzed by the profiles and standards development organizations in their prior work.

Error! Reference source not found. illustrates the main steps of this methodology, where the knowledge of the array of Business Scenarios come from the stakeholders and a validation performed through their experiences (i.e., issues and gaps corrected based on their feedback).

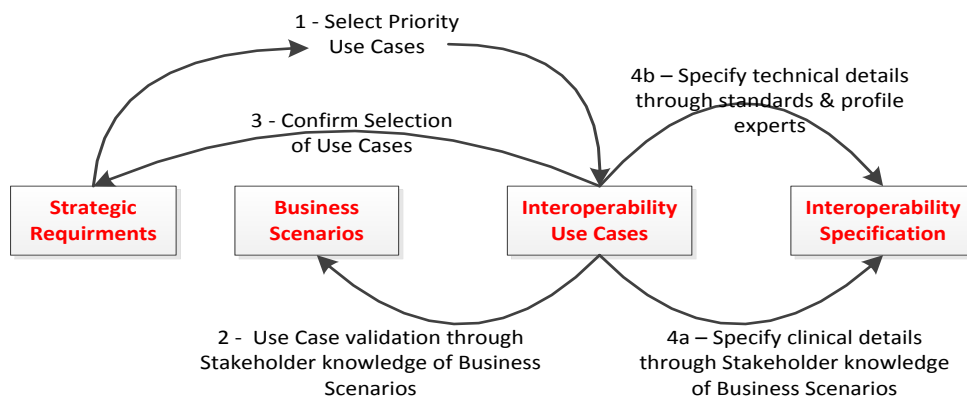

Figure 1.1-2 Methodology Steps for the eHealth Standards-Based Interoperability Specifications and Policy Project

The Interoperability Use Cases provide a description of the workflows that need to be addressed and the main exception situations. They are not expected to cover all design details in term of error codes, data element specification and terminology code sets to be used.

This level of detail is appropriately addressed in the Interoperability Specification (See step 4a in the diagram methodology steps). It contains the detailed design specification against which implementations will be tested and certified. An Interoperability Use Case is a scoping document and is a stepping stone to the development of a Saudi eHealth Core Interoperability Specification and supporting Saudi eHealth Core Interoperability Specifications. Together these Interoperability Specifications cover five complementary aspects:

- The specification of the information transport running above the Internet TCP/IP layer.
- The specification of one or more data exchange services suitable for the workflow needed by the Use Case that runs over the above transport.
- The specification of one or more information content data structure enabling the structured representation of the health information data elements and their specific attributes to be conveyed.
- The specification of one set of coded values, each to be placed into a specific attribute of a selected data elements to be conveyed by the above data structure.
- The specification of the technical measures to ensure security and privacy of the information conveyed and accessed.

These Interoperability Specifications and the standards and profiles they reference are designed to form a complete specification covering all aspects necessary to achieve the standards-based exchange of information across the HIE Platform (except for interoperability policy matters that are addressed separately). The Saudi eHealth Interoperability Specifications are the authoritative documents for software implementers and system deployment teams.

As a consequence, rigorous but concise test plans (i.e., a set of test scripts) may be developed and when executed result in a reasonable assurance of interoperability between successfully tested systems. Such testing for interoperability may be performed against test tools as well as between systems under test; a combination widely accepted as the most efficient testing process. These test plans and test tools provide closure against the Core Interoperability Specifications and Supporting Interoperability Specifications, thus bringing the necessary level of quality in interoperable IT systems development and deployment.

This is depicted in Figure 1.1-3 Verification of Conformance to a Core Saudi eHealth Interoperability Specification

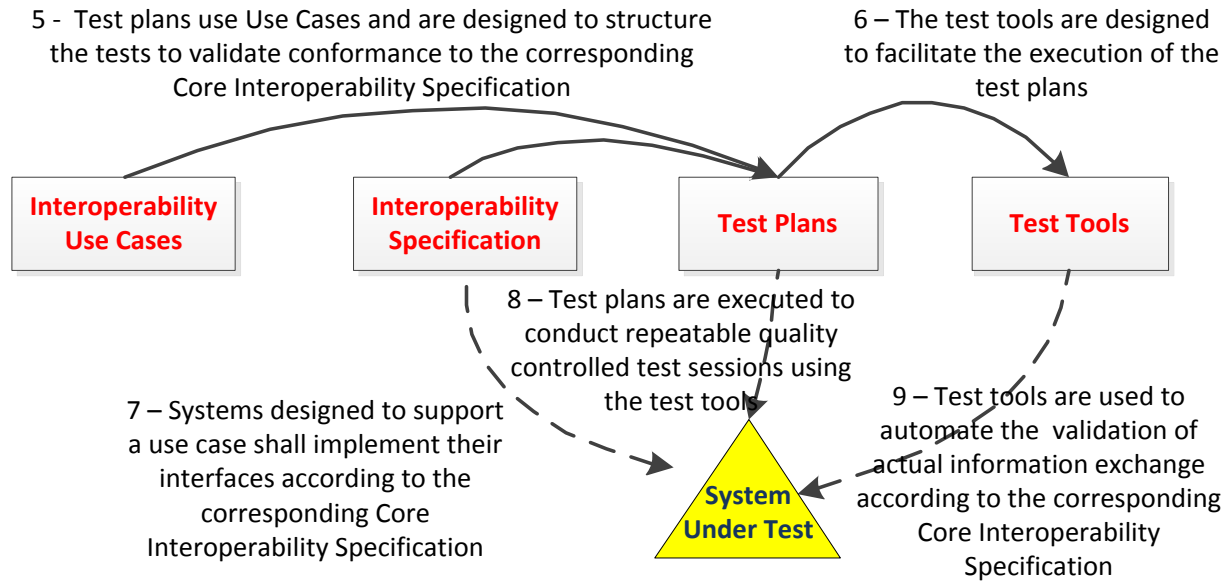

Figure 1.1-3 Verification of Conformance to a Core Saudi eHealth Interoperability Specification

IMAGING BASED INTEROPERABILITY USE CASES

1. SHARING IMAGES AND IMAGING REPORTS - INTEROPERABILITY USE CASE

1.1 Description

This Use Case describes the ability to share imaging reports and images via the SeHE. This includes images and reports acquired on a broad range of imaging modalities. Two common examples are to store and/or access images and reports about a patient's current imaging procedure and the ability to access images/reports from imaging studies previously performed for that patient.

The data content shared are:

1. DICOM SOP Instances – various DICOM objects such as images, key image notes, presentations states, evidence documents, etc.
2. Imaging Manifest - a DICOM SOP Instance (i.e. Key Object Selection) that describes and collects references to the images and associated DICOM objects generated for a patient's imaging study.
3. Imaging Report – the physician's diagnostic report associated with the imaging study identified in its Imaging Manifest.

Note – Managing the images and report within SeHE requires the use of the patient's national Health ID. This can be obtained via the KSA-Wide Patient Demographic Query Use Case (see Table 1.3-6 Use Case Dependencies

for more details).

1.2 Use Case Benefits

- Timely access to a patient's imaging studies from a broad range of imaging modalities across KSA, used by facilities such as hospitals, primary care centers.
- Timely access to a patient's diagnostic reports resulting from the interpretation of imaging studies across KSA.
- Reduces duplicate imaging tests for patients.
- Enables the sharing of images to enable remote tele-radiology services.

1.3 Actors

The Actors defined in this Use Case (*see note) are described in Table 1.2-1 Actors

Table 1.2-1 Actors

ACTOR NAME	DESCRIPTION	EXAMPLE REAL-WORLD IT SYSTEMS
Imaging Information Source	This Actor is a producer and publisher of imaging documents. This includes a manifest document (i.e. identifies the series of images within an imaging study), images and imaging reports.	Radiology Information System (RIS) Picture Archiving and Communication System (PACS) PACS Viewers
Imaging Information Consumer	The Actor queries and retrieves imaging manifest documents and retrieves the images referenced within that manifest from the Imaging Repository actor.	Radiology Information System (RIS) Picture Archiving and Communication System (PACS) PHC EMR Systems Oncology Information Systems PACS Viewers
Imaging Report Consumer	This Actor is responsible for querying and retrieving imaging diagnostic reports from the Imaging Repository.	Radiology Information System (RIS) Picture Archiving and Communication System (PACS) PHC EMR Systems Oncology Information Systems PACS Viewers
Imaging Repository	This Imaging Repository stores the imaging manifests, images and the imaging reports. It also maintains metadata about each registered document. The Imaging Repository responds to Actors that query and retrieve imaging manifests, images and report documents.	SeHE System

*Note – It is very common for Use Cases to rely on Actors from other Use Cases when being executed in the real world. For example, to obtain a patient’s unique Health ID, systems implementing this Use Case support the Patient Demographics Consumer Actor from the KSA-Wide Patient Demographic Query Use Case. Such related but important Actors are not described here, but in the Use Cases where they are defined see Table 1.3-6 Use Case Dependencies for more details.

1.4 Main Flow of Events

Figure 1.2-1 Sharing Images and Imaging Reports Main Process Flow

and the text below provides a typical high level example of the information workflow for sharing a patient's images and imaging reports. It uses the example of the interaction between a Hospital and a PHC.

The patient visits a hospital for an imaging procedure. The imaging study is performed and the images, the imaging manifest and the diagnostic report are created. The radiologist stores the images, report and imaging manifest using a RIS/PACS (acting as an Imaging Information Source) into the Imaging Repository. The information is available for use by all approved stakeholders that have access to SeHE (acting as an Imaging Repository).

Note: An Image Manifest is a document that describes and collects references to the images generated for a patient's imaging study. See Section 1.7 for more details.

The patient visits the PHC and the primary care physician uses the local PHC EMR (acting as an Imaging Information Consumer and Imaging Report Consumer) to query the Imaging Repository for the imaging report and image manifest generated during the patient's recent outpatient stay. The physician then uses the PHC EMR (acting as an Imaging Information Consumer and Imaging Report Consumer) to retrieve the report, manifest and images for review. He also may retrieve relevant prior images and/or reports. Patient follow-up care is given based upon these reports and images.

Note: One typical example is provided, other workflows scenarios can be read in Section 1.7.

Note: For a typical flow of events, the hospital publishes the image manifest, images and report *after* the imaging study and report are completed (report approved). However there are exceptions to this workflow. For example, images have been acquired for a trauma case in Hospital A, the images are read and a decision is made to move the patient to an advanced trauma center in Hospital B. Although the imaging report has not been approved (i.e. not stored on the Imaging Repository), the images must be shared with the physicians in Hospital B. Therefore, Hospital A must publish the images and image manifest to the Imaging Repository *before* the report has been approved and shared.

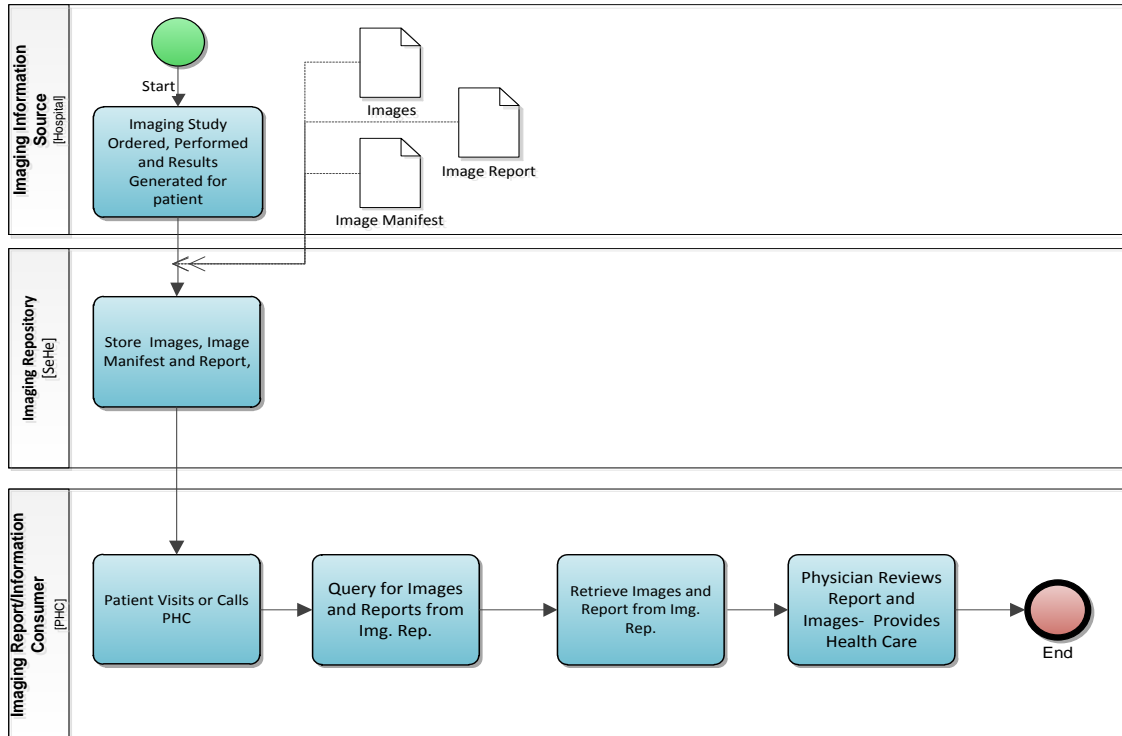

Figure 1.2-1 Sharing Images and Imaging Reports Main Process Flow

1.5 Alternative Flow of Events

1.5.1 Image Sharing With Notification of Document Availability Flow

Figure 1.2-2 Sharing Images and Imaging Reports Workflow with Notification of Document Availability and the text below illustrates an example activity diagram similar to the previous main workflow example but includes the ability to be notified when the imaging documents are accessible within the Imaging Repository.

Based upon healthcare provided at a PHC, the patient is referred to the hospital for an imaging procedure (such as an outpatient visit for a radiology procedure). An imaging study is performed and the images, the imaging manifest and the diagnostic report are created. The radiologist stores the images, report and imaging manifest using a RIS/PACS (acting as an Imaging Information Source) into the Imaging Repository. The information is available for use by all approved stakeholders that have access to SeHE (acting as an Imaging Repository).

When the patient's imaging report is created by the radiologist at the hospital, a notification is provided to let the primary care physician's EMR (acting as an Imaging Information Consumer and Imaging Report Consumer) know the imaging manifest and

report are available in the Imaging Repository for the patient. This facilitates the PHC EMR to retrieve the documents which then enables the physician to review the images and report as part of follow up care to the patient.

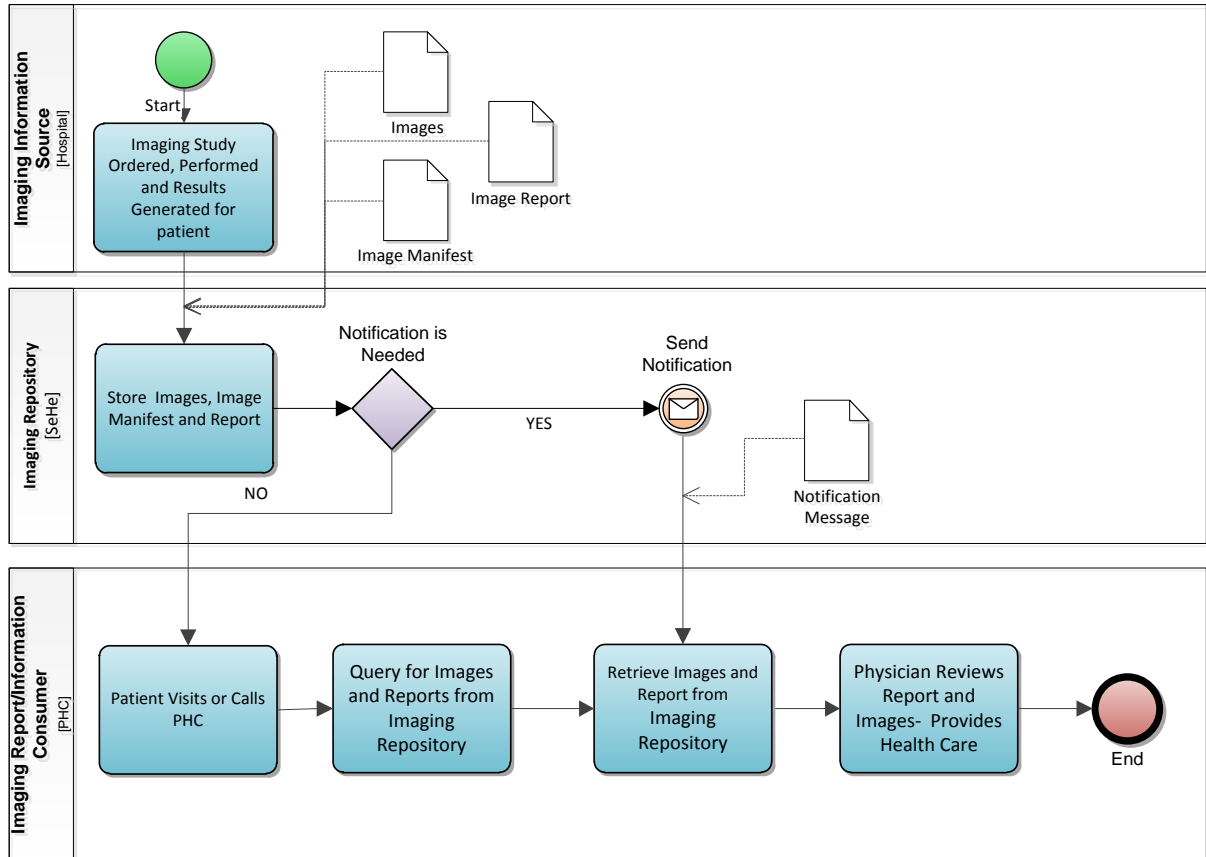

Figure 1.2-2 Sharing Images and Imaging Reports Workflow with Notification of Document Availability

1.5.2 Amended Report Flow

Figure 1.2-3 Report Amendment Typical Process Flow and the text below provides a typical high level example of the information workflow for the scenario when an imaging report has been updated via an amendment.

The workflow described in the Main Flow of Events (see Section 1.4) is a pre-condition to creating an amended report and not documented in this section.

The radiologist that created the original report determines that important information was left out of the report. The radiologist creates an amended report in the RIS/PACS to add the missing information. The radiologist stores the amended report using the RIS/PACS (acting as an Imaging Information Source) into the Imaging Repository. This new report references the original report and informs the Image Repository that it is an amendment

to the original. This information is used by the Image Repository to manage the two versions (i.e. deprecate the original image report). The physician is notified that an amended report was created (either automatically from the Image Repository or manually from the hospital). The physician then uses the PHC EMR (acting as an Imaging Report Consumer) to retrieve the amended report for review. Patient follow-up care is given based upon the new report.

Note – There are real world situations where imaging departments (e.g. RIS/PACS, Tele-Radiology Service) need to delete images due to poor quality or add images because of additional reconstruction protocols. This requires storing the additional images and to amend the study image manifest. This uses the same network services that have been explained, even though they are performed for completely different reasons; this is why it is not shown as a distinct alternative flow of events.

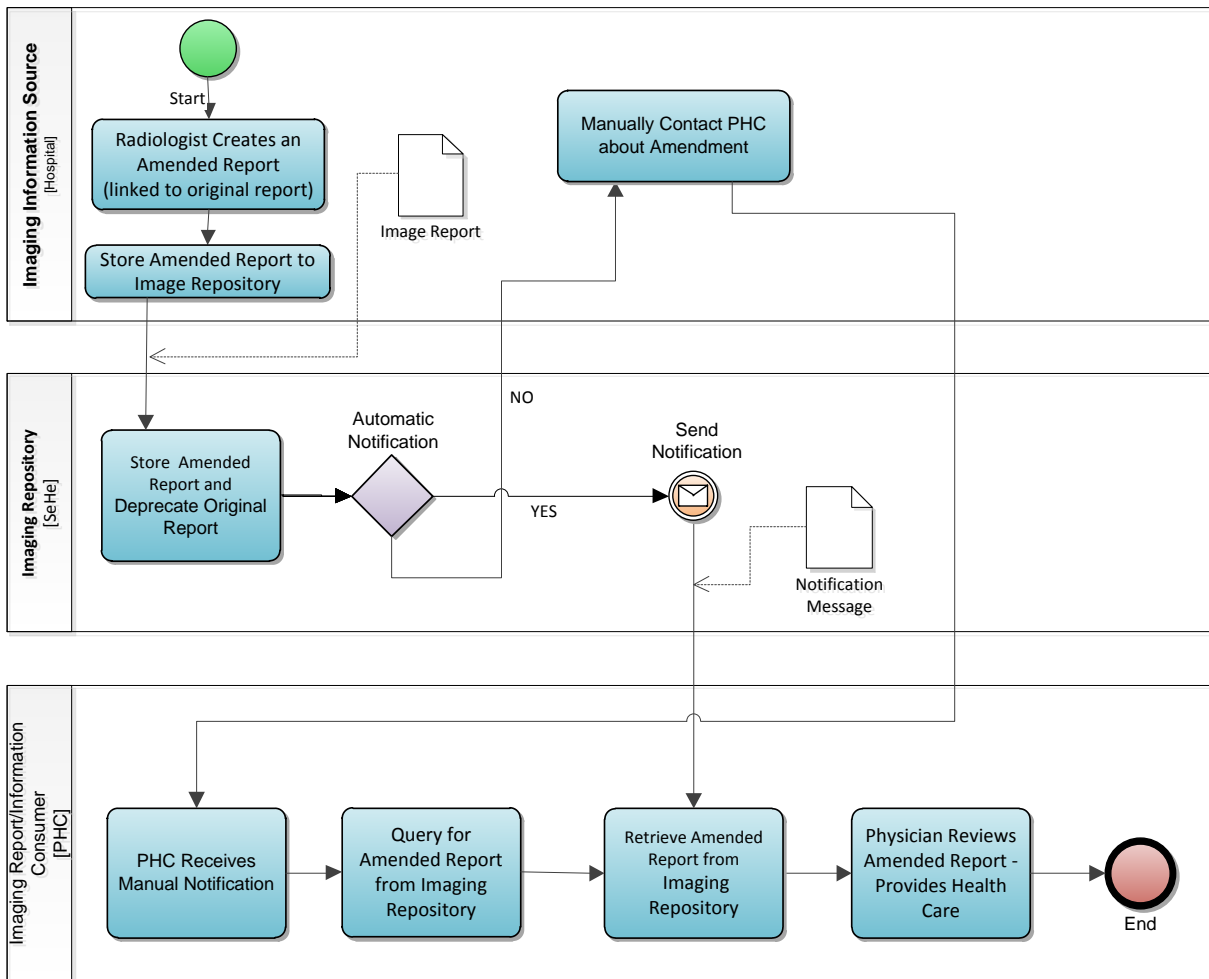

Figure 1.2-3 Report Amendment Typical Process Flow

1.6 Exceptions Work Flow

N/A

1.7 Specific Workflow Scenarios

The following sections provide short descriptions of scenarios that complement the use case flow of events by using the defined transactions in specific ways. Some of these scenarios highlight variants to the use case main flow of events while others describe interactions with local workflow situations that are beyond the scope of the use case but consistent with it. These workflow scenarios are not intended to be an exhaustive list.

1.7.1 Scenario 1: Basic –Pre-fetching For a New Radiology Order

A patient is scheduled for a radiology imaging study at local Hospital A. A search is performed to determine if related image sets and/or reports for the patient are available in the Imaging Repository. After a successful match, the images/reports are automatically transmitted to the local hospital for review.

1.7.2 Scenario 2: Ad Hoc or On-Demand Image Fetch From Imaging Repository

Ad hoc or “select from a list” queries require a user interface. The user interface is populated via a patient-based query made from the Healthcare Provider and/or Organization to the Imaging Repository (i.e., get a list of all imaging information that may be relevant to this patient). This user interface integration is outside the scope of this specification although the tag morphing discussion will apply to import the images and reports. For example, the local Patient ID may be different in separate Healthcare Organizations than the national Health ID.

1.7.3 Scenario 3: Pre-Fetch Of Relevant Priors from Imaging Repository Into Local Hospital Initiated By Patient Visit (non-radiology workflow)

There are other clinical areas such as oncology or neurology which need to view imaging studies and reports from multiple sites. For example, a follow-up, second opinion, consult, or treatment, visit may benefit from automatic pre-fetching based on scheduling or an arriving message from a non-radiology scheduling system. Therefore a search is performed based upon the patient and the information in the scheduling and/or arrival message. After a successful match, the images/reports are automatically transmitted to the search location.

1.7.4 Scenario 4: Report-Only Prior Retrieval

There may be cases where physicians (e.g. referring physicians) only want to see prior reports and not sift through thousands of images. An ad hoc (on demand) query based on the patient’s Health ID would be sufficient to deliver the list of available reports. When the retrieve is performed, the application only requests the reports for the specific patient be transferred.

1.7.5 Scenario 5: Report is amended after pre-fetch has occurred to local system

The local system query and retrieves a patient's report from the Imaging Repository. There is a race condition which exists where a report could be amended after it has been pre-fetched and stored locally to a different institution. It is advisable at the time of access by the local clinician to have the system in the institution that has pre-fetched this report to re-query the Imaging Repository to verify that it has not been deprecated and replaced by an amended report. If the pre-fetched report has been deprecated, then the local system retrieves the amended report.

1.7.6 Scenario 6: Images are added/changed after pre-fetch has occurred to local system

The local system query and retrieves a patient's images from the Imaging Repository. There is a race condition which exists where additional images could be created or annotated after the study has been pre-fetched to a different institution. It is advisable at the time of access by the local clinician to have the system in the institution that has pre-fetched this imaging manifest to re-query the Imaging Repository to verify that an amended imaging manifest has not been deprecated and replaced by an amended manifest pointing at additional images. If the pre-fetched report has been deprecated, then the local system retrieves the additional images, and/or associated documents.

1.7.7 Scenario 7: Emergency patient comes in and is imaged at local site

If an emergency patient is unknown, the operator uses a web registration application to obtain a temporary Health ID. The temporary Health ID is used to identify the images/imaging reports generated for the patient and can be published to SeHE. If the operator is unable to access the web registration application (i.e. the patient's condition is so critical the operator cannot take time to register the patient), local identifiers are used. When using local identifiers, images that have been acquired (and possibly reported) are to remain local. Upon identifying the patient, the local system queries the SeHE System to obtain the Health ID for the patient. The Health ID is used for the patient's records and the images/reports will be shared in the Imaging Repository.

1.7.8 Scenario 8: An Identified Emergency Patient Comes In and Is Imaged But Not Yet Reported, When The Patient Needs To Be Transferred To Another Site

If the patient is identified and their national Health ID matched, these images may be shared using its Health ID before the report is completed. This will allow the other site to use the images from the original site and not repeat the image acquisition. This is accomplished by having the original site store the images on the Imaging Repository. When the patient arrives at the second site, it uses the patient's Health ID to query and retrieve the images from the Imaging Repository.

1.7.9 Scenario 9: An unidentified emergency patient comes in and is imaged but not yet reported, when the patient needs to be transferred to another site

If the patient is unidentified, the patient has a local temporary ID in the first site, with no national Health ID matched. The patient will receive another local ID after being transferred to the other site. There is no concrete link between these patient IDs, except for the physical existence of the patient. These images are not shared in SeHE until either a temporary or permanent Health ID is obtained for the patient.

1.7.10 Scenario 10: Split Imaging Procedures

For various imaging procedures it is useful for local PACS systems to “split” the imaging procedure. For example, a patient is having a CT “chest, abdomen, and pelvis” imaging study. Quite often this study is acquired with one DICOM imaging study. However, some PACS systems do not wish to keep this type of procedure as one imaging study and will “split” the study, for example create one study for each body part (i.e. three studies).

1.8 Service Model

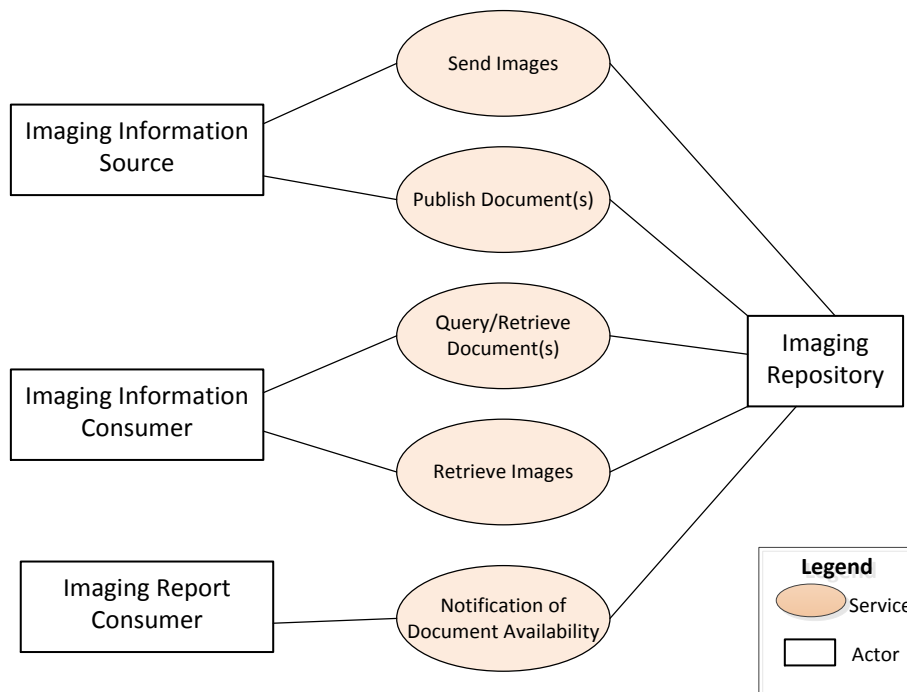

Figure 1.2-4 Sharing Images and Imaging Reports Service Model

1.9 Service Description

The Services defined in this Use Case are described in Table 1.2-2 Services

Table 1.2-2 Services

SERVICE NAME	DESCRIPTION
Publish Document(s)	Publish Document(s) is used by the Imaging Information Source to provide a set of documents (image manifests, reports) to the Imaging Repository and to request that it stores these documents and register their metadata.
Send Images	This service is used by the Imaging Information Source to transmit sets of images to the Imaging Repository.
Query/Retrieve Document(s)	This Service is Used by the Imaging Information Consumer and Imaging Report Consumer Actors to query the Imaging Repository for information about documents stored and indexed by metadata. The Actors also retrieve one or more relevant documents (i.e. imaging reports and image manifests).
Notification of Document Availability	This service is issued by the Imaging Repository to notify an Imaging Information Consumer actor of an imaging report and/or imaging manifest of interest that is available to be retrieved.
Retrieve Images	This service is used by the Imaging Information Consumer to retrieve sets of images from Imaging Repository Actors.

1.10 Pre-Conditions

Table 1.2-3 Pre-Conditions

identifies pre-conditions for this Use Case.

Table 1.2-3 Pre-Conditions

ACTOR NAME	SERVICES	DESCRIPTION
All Actors	All Services	It is expected that all services initiated or provided by this actor operate in accordance to the Saudi eHealth Interoperability Policies and Interoperability Specifications.
Imaging Information Source	Publish Documents	As a result of an imaging order by an authorized provider, an imaging study has been performed on a patient. Resulting in images (for discussion on the different formats supported see Table 1.2-7 Image Manifest Data Content), an image manifest and diagnostic report.
	Send Images	
	Send Images	Images may be stored in an Imaging Repository (e.g. a dedicated archive space for the Imaging Information Source in the Saudi eHealth Exchange System).

1.11 Post-Conditions

Table 1.2-4 Post Conditions

identifies post-conditions for this Use Case.

Table 1.2-4 Post Conditions

ACTOR NAME	SERVICES	DESCRIPTION
Imaging Repository	All services	Images, Imaging Manifests and Reports are available for access
Imaging Information Consumer	Receive Images	It is expected that images retrieved from the SeHE Imaging Repository are able to be displayed, such as: <ul style="list-style-type: none">• In the case of relevant priors, “side by side” display with images from the new imaging study (i.e. comparison of the old and new images) is expected.• In the case of remote consultation and other scenarios, the ability to retrieve and display images on-demand is expected.

1.12 Data Requirements

This section defines the general scope of the type of data needed for this Use Case. However, it does not define the entire detailed data set as this will be discussed in the Saudi eHealth Interoperability Specification design document.

1.12.1 Image Report Data

The information content of the Image Report includes diagnostic interpretation of imaging studies for patients. It is motivated by the need to have easy access for reviewing radiology reports within the KSA. This Use Case describes two types of radiology reports, they are:

- A “Displayable Radiology Report” that includes structured header data and ready to display content for the purpose of viewing a radiology report in the same format as created by the source. Table 1.2-5 Displayable Radiology Report Data Content
- provides a minimum set of information content for the “Displayable Radiology Report”.
- A “Basic Structured Radiology Report” that includes structured header data and coded sections heading titles (such as History, Impressions, Findings, Conclusions, etc.). Table 1.2-6 Basic Structured Radiology Report Data Content
- provides a minimum set of information content for a radiology report with structured section headings.

It is expected that an Imaging Information Source creates and stores both report formats. It is expected that an Imaging Report Consumer retrieves and displays one and/or both report formats.

Table 1.2-5 Displayable Radiology Report Data Content

IMAGE REPORT MODULES	DESCRIPTION	TEXT/CODED
Source and context information of the Imaging Report	Includes data such as: <ul style="list-style-type: none"> • Patient demographics. • Hospital organization information. • Provider information for those who provider care. • Encounter for which this imaging procedure was performed. • Type of imaging procedure performed. • Author and custodian of the document. • Other 	Text and Coded
Document Body (Diagnostic Interpretation)	Contains a physician’s textual interpretation of one or more related imaging studies in a ready-for-display form (PDF).	Text

Table 1.2-6 Basic Structured Radiology Report Data Content

IMAGE REPORT MODULES	DESCRIPTION	TEXT/CODED
Source and context information of the Imaging Report	Includes data such as: <ul style="list-style-type: none"> • Patient demographics. • Hospital organization information. • Provider information for those who provider care. • Encounter for which this imaging procedure was performed. • Type of imaging procedure performed. • Author and custodian of the document. • Other 	Text and Coded
Document Body (Diagnostic Interpretation)	Contains a physician’s textual interpretation of one or more related imaging studies using coded section headings such as History, Impressions, Findings, Conclusions, etc.	Text and Coded (Section Headings)

1.12.2 Image Manifest Data

The information content of the Image Manifest includes the references to the images of the study organized by series. Table 1.2-7 Image Manifest Data Content

provides a minimum set of information content.

Table 1.2-7 Image Manifest Data Content

ATTRIBUTE LOGICAL NAME	LOGICAL DEFINITION	TEXT/ CODED
Health ID or Local Patient ID	An ID that identifies the patient for which this imaging manifest references.	ID Format
Patient's Name	The individual to whom the health record refers.	Name Formatted
Gender	The administrative sex of the patient.	Coded
Birth Date	The date of the birth of the patient.	Date Formatted
Study Date	Date the study started.	Date Formatted
Study Time	Time the study started.	Time Formatted
Accession Number	The RIS generated order number for the imaging procedure(s) in the manifest.	ID/OID Formatted
Retrieve Location UID	Unique identifier of the system where the DICOM Object(s) may be retrieved on the network.	UID Formatted
Study Instance UID	Unique identifier for the study.	UID Formatted
Referenced Series Sequence	References one or more series within the imaging study, using the attribute Series Instance UID for each series referenced.	Sequence and UID Formatted
Referenced Image Sequence	References one or more DICOM images or other DICOM objects within a series, using the attributes Referenced SOP Class UID and Referenced SOP Instance UID.	Sequence and UID Formatted

1.13 Assumptions and Dependencies

Table 1.2-8 Use Case Dependencies

identifies and describes Use Cases which this Use Case depends upon for information workflow.

Table 1.2-8 Use Case Dependencies

USE CASE NAME	DEPENDENCY ASSUMPTIONS
KSA-wide Patient Demographic Query	The KSA-Wide Patient Demographic Query Use Case is required to obtain the Health IDs and demographic information for the patient. It is used to ensure that the nationwide Health ID is used to register image manifests and reports for the correct patient. It provides consistent data into the imaging information.
Healthcare Provider Directory Query	The Healthcare Provider Directory Query Use Case is used to obtain referral provider and organizational information.

1.14 Special Requirements

N/A

1.15 Notes and Issues

1.15.1 Three Configurations Using Saudi National Imaging Repository

In the Saudi eHealth Strategy, MOH has defined a national Tele-Radiology Service to be deployed within the KSA. This has been analyzed as part of these Imaging Domain Use Cases. The intent of this section is to show how the Sharing of Images and Imaging Reports and the Tele-radiology Order Use Case may be combined to achieve the proposed system configurations.

The system configurations are shown in Figure 1.2-5 Configurations Using Imaging Repository

- The image repository is shown in the middle and is part of the SeHE System.
- The “red dotted line” shows the SeHE interfaces that are being standardized by these imaging Use Cases.
- Only the “red” standard interfaces are within scope of this document (i.e. the ability to store/retrieve images and imaging reports and the ability to create and manage tele-radiology orders). The “blue dotted lines” are proprietary interfaces.

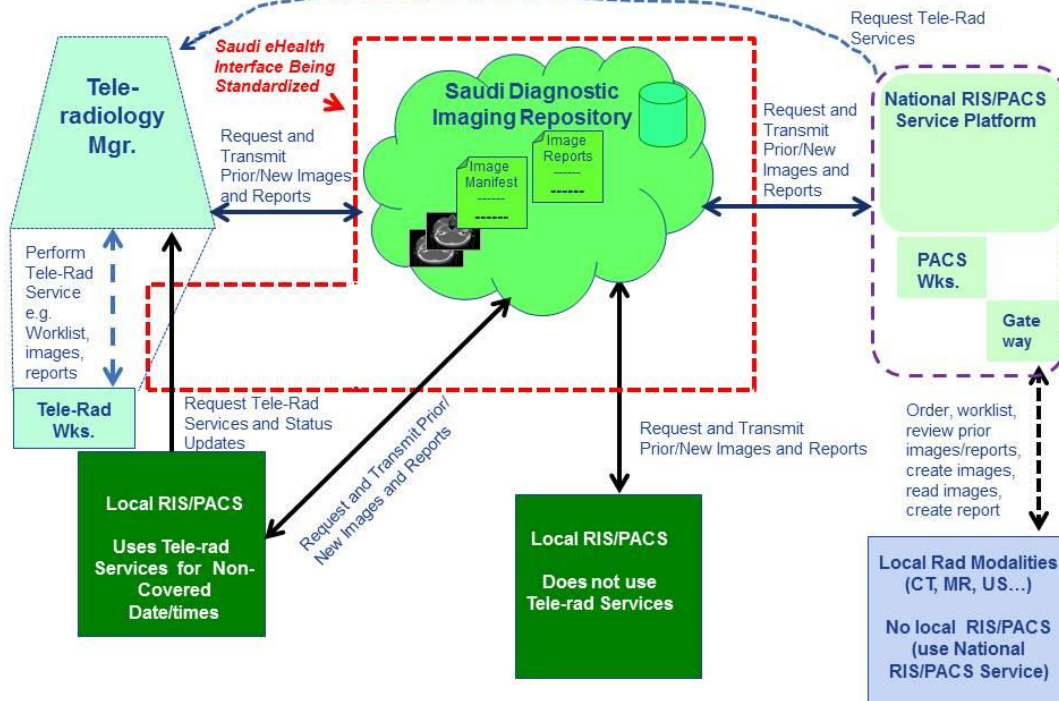

Figure 1.2-5 Configurations Using Imaging Repository

1. Local RIS/PACS that does not use the tele-radiology service (middle configuration):
The typical example would be a hospital RIS/PACS. It interacts with the SeHE Imaging Repository as follows:
 - a. A physician orders an imaging study and images are acquired. The radiologist retrieves relevant prior images/reports and thus uses the Query/Retrieve Document(s) and Retrieve Image(s) services to access the information from the Imaging Repository. The radiologist then creates a diagnostic report. The images are stored to the Imaging Repository using the Send Image(s) service. The image manifest and report are stored to the imaging repository using the Publish Document(s) service. These services are defined in the Sharing Images and Imaging Reports Use Case (See Section 1.9 for details).

2. Local RIS/PACS that uses the tele-radiology service as a backup (left configuration):
The typical example is a hospital RIS/PACS that is configured to access the services of the Tele-Radiology Service. It interacts with the Saudi Imaging Repository as follows:
 - a. When radiologists are available, the local RIS/PACS is being used, thus the workflow is the same as above (i.e. Query/Retrieve images and reports, Send Images, Publish Documents. For times when the radiologists are not available, the tele-radiology service may be used. An example workflow is:
 - i. A physician orders an imaging study at the hospital (outside the Use Case).
 - ii. The images and image manifest are created and stored on the imaging repository.
 - iii. The hospital issues a tele-radiology order.
 - iv. The tele-radiology manager receives the order and manages the interpretation process (i.e. workstation, interpretation work list, images, creation of reports, etc.) (outside the Use Case).
 - v. A remote radiologist, using the tele-radiology workstation, creates the report (outside the Use Case).
 - vi. The tele-radiology manager stores the report on the imaging repository and sends a “completed” order status to the local RIS/PACS.
 - vii. The local RIS/PACS retrieves the report to store locally.

The images and reports are shared using the services from the Sharing Images and Imaging Reports Use Case (as mentioned above). The tele-radiology order is created and managed (i.e. set to completed) using the Manage Order service from the Tele-Radiology Order Use Case.

3. No local RIS/PACS, therefore uses the National RIS/PACS and the Tele-radiology Services (right configuration):

4. Since there isn't a hospital RIS/PACS, the radiologist utilizes the National RIS/PACS Service workstation to review images and to generate imaging reports. The workflow using the National RIS/PACS Service is the similar to the workflow of a hospital RIS/PACS. It interacts with the Saudi Imaging Repository as follows:
 - a. The National RIS/PACS Service Platform is used as if a local RIS/PACS is on site (outside the scope of Use Case).
 - b. A gateway acts as a RIS/PACS interface (i.e. communicates with local HIS & Modality) (outside the scope of Use Case).
 - c. The gateway uses the same common standards as a hospital RIS/PACS would (e.g. HL7 and DICOM). These standards are very well understood and implemented in several KSA hospitals (outside the scope of Use Case)
 - d. Query/Retrieving prior images and reports, creating new images and storing the images on the imaging repository uses the Sharing Images and Imaging Report services.
 - e. The tele-radiology service may be used when a local radiologist is not available. However it does not need to use the standardized service from the Tele-Radiology Order Use Case, as the National RIS/PACS Service provides this feature using proprietary communications (i.e. as defined by the Saudi eHealth strategy).

2. TELE-RADIOLOGY ORDER – INTEROPERABILITY USE CASE

2.1 Description

This Use Case supports the submission of a tele-radiology order to a remote tele-radiology service via the SeHE System. Orders are created by Health IT systems (e.g., hospital RIS/PACS or National RIS/PACS) that manage the fulfillment of an imaging procedure ordered for local patients (such as within a hospital). However, in this Use Case, no radiologists are available to perform the reading of the acquired imaging study. The images acquired may then be shared for diagnosis via the National Tele-radiology Service. A radiologist working on the tele-radiology service reads the images and creates an imaging report, imaging manifest and stores them on SeHE. The source of the tele-radiology order (e.g. hospital RIS/PACS or National RIS/PACS) can now retrieve the report.

The images and reports are made accessible to other healthcare providers such as a primary healthcare physician via the Sharing Images and Imaging Report Use Case (see Section 1).

2.2 Use Case Benefits

- Use of tele-radiology service when local radiologists are not available, such as evening non-availability, weekend non-availability, off-load heavy workload, an imaging study that is based upon an advanced procedure not supported by local radiology staff.
- Timely access to imaging orders and images acquired throughout the KSA by imaging centers in the KSA that provide tele-radiology reading services.
- Facilitate timely generation of imaging results for patients for hospitals that may not have the specialized radiologists on call 24 hours a day.
- Consistent generation of imaging orders using the same order (i.e. procedure) codes from all KSA stakeholders (i.e. care providers from hospitals, primary care centers, etc.).
- Reduces errors in patient care related to imaging orders and results.

2.3 Actors

The Actors defined in this Use Case² are described in

Table 1.3-1 Actors

.

² It is very common for Use Cases to rely on Actors from other Use Cases when being executed in the real world. For example, to obtain a patient's unique Health ID, systems implementing this Use Case would support the Patient Demographics Consumer Actor from the KSA-Wide Patient Identification Query Use Case. Such related but important Actors are not described here, but in the Use Cases where they are defined see Table 1.3-6 Use Case Dependencies

for more details

Table 1.3-1 Actors

ACTOR NAME	DESCRIPTION	EXAMPLE REAL-WORLD IT SYSTEMS
Tele-Radiology Order Creator	This Actor is responsible for the creation of coded tele-radiology orders and transmitting the orders to the Tele-Radiology Order Forwarder. It is also responsible to manage the order status updates such as new order, in progress, completed, cancel and aborted.	Point of Care Systems such as: <ul style="list-style-type: none"> • Radiology Information Systems (RIS)
Tele-Radiology Order Fulfiler	This Actor is responsible for receiving a coded tele-radiology order from the Tele-Radiology Order Forwarder for the reading and reporting of the locally acquired images for a patient. It is also responsible to provide updates to the order, such as in progress, completed or aborted.	National Tele-radiology Service Radiology Information Systems (RIS) Picture Archive Communication System (PACS)
Tele-Radiology Order Forwarder	This Actor is used to forward tele-radiology orders and status updates between the Tele-Radiology Order Creator and Tele-Radiology Order Fulfiler Actors. This Actor is only performing a store and forward of the messages to the target destination.	SeHE System

2.4 Main flow of Events

Figure 1.3-1 Tele-Radiology Order Typical Flow and the text below provide a typical high level example of the information workflow for creating a patient’s tele-radiology order.

The patient visits a hospital and it is determined that an imaging procedure is required. The hospital physician orders an imaging procedure (via the local RIS/PACS) for the patient using standardized order code(s) for the imaging procedure. The hospital radiologists are not available to read the imaging study so the hospital transmits the images to the tele-radiology service using the DICOM storage service (how this is accomplished is outside the scope of this Use Case). It then uses the RIS/PACS (acting as a Tele-Radiology Order Creator) to issue a tele-radiology order (which references the imaging study) to the Tele-Radiology Order Forwarder Actor. The Tele-Radiology Order Forwarder Actor forwards the order to the remote Tele-radiology Service (acting as a Tele-Radiology Order Fulfiler).

The Tele-radiology Service (acting as a Tele-Radiology Order Fulfiler) receives the forwarded order and generates an internal “interpretation work list” that a radiologist supporting the Tele-Radiology Service may accept.

Note: The integration of multiple local RIS/PACS interpretation processes with the Tele-radiology service interpretation process requires distributed workflow management standards that are “emerging” but not mature enough for implementation. This could be covered by a future Use Case. In the meantime, the radiologist that performs tele-radiology services may need a second workstation.

The radiologist interprets the imaging study using the Tele-radiology Service (i.e. generates an imaging report and imaging manifest). How this is accomplished is outside the scope of this Use Case and is a proprietary solution (as defined by the Saudi eHealth strategy). Relevant prior images/reports may also be retrieved via the workflow defined in the Sharing of Images and Imaging Report Use Case.

The Tele-Radiology Order Fulfiler uses the Tele-radiology Service to store the imaging report, images and imaging manifest in the Imaging Repository (as defined in the Sharing of Images and Imaging Report Use Case). Then the status of the tele-radiology order is updated to “completed” by the Tele-Radiology Order Fulfiler.

The hospital RIS/PACS receives the “completed” status (acting as a Tele-Radiology Order Creator). This informs the hospital that the order is available within the Imaging Repository. The RIS/PACS retrieves the imaging report from the Imaging Repository (as defined in the Sharing of Images and Imaging Report Use Case). The report is reviewed and patient care is provided.

Only one typical example is provided, but similar information workflow could occur.

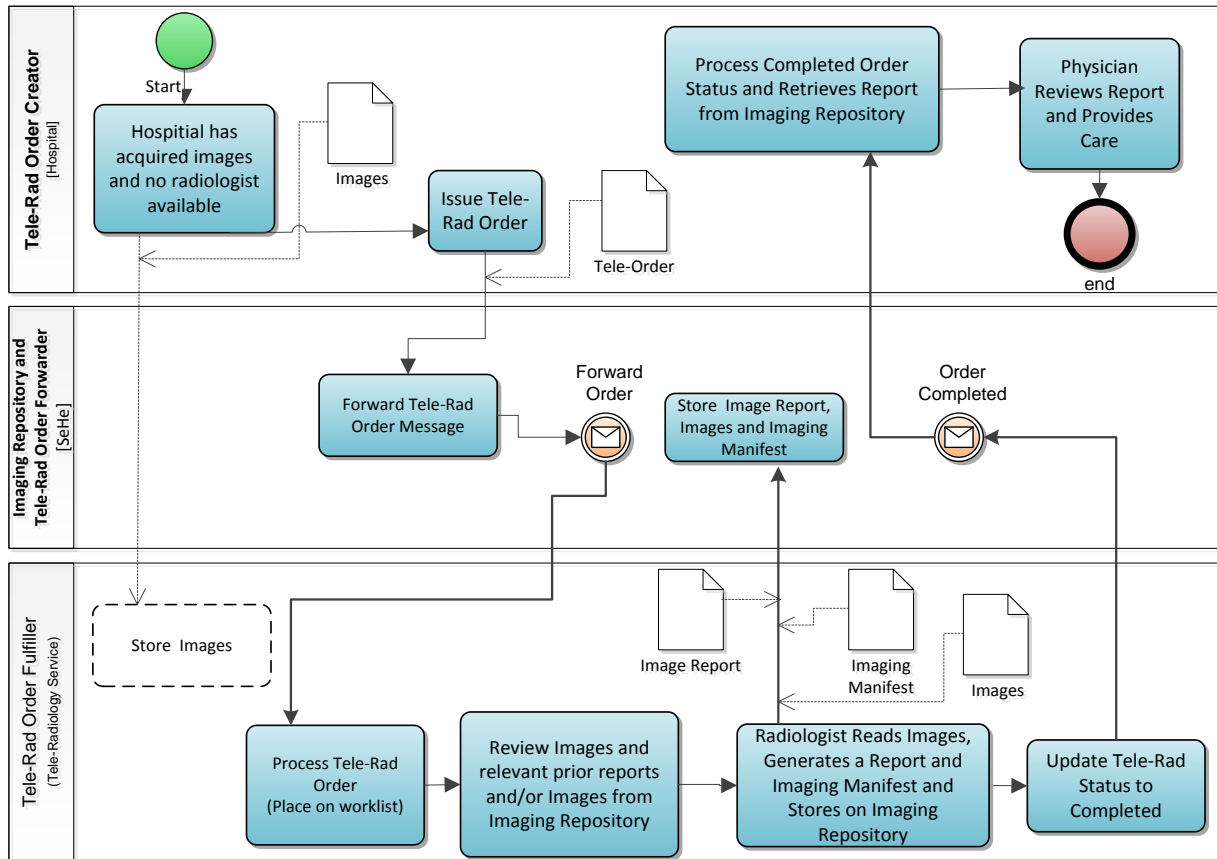

Figure 1.3-1 Tele-Radiology Order Typical Flow

2.5 Exceptions Work Flow

2.5.1 Order Canceled

Figure 1.3-2 Tele-Radiology Cancel Order and the text below provides a typical high level example of the information workflow for canceling a patient's tele-radiology order.

The patient visits a hospital and it is determined an imaging procedure is required. The hospital physician orders an imaging procedure (via the local RIS/PACS) for the patient using standardized order code(s) for the imaging procedure. No local radiologist is available to read the imaging study so the hospital transmits the images to the tele-radiology service using the DICOM storage service (how this is accomplished is outside the scope of this Use Case). It then uses the RIS/PACS (acting as a Tele-Radiology Order Creator) to issue a tele-radiology order (which references the imaging study) to the Tele-Radiology Order Forwarder Actor. The Tele-Radiology Order Forwarder Actor forwards the order to the remote Tele-radiology Service (acting as a Tele-Radiology Order Fulfiler).

The above flow is the same as the Main Flow of Events. The text below describes an example workflow to cancel the tele-radiology order.

A local radiologist from the hospital becomes available to interpret the imaging study. He uses the RIS/PACS (acting as a Tele-Radiology Order Creator) to send a “canceled” order status update to the Tele-Radiology Order Forwarder Actor. The Tele-Radiology Order Forwarder Actor forwards the “canceled” order to the remote Tele-radiology Service (acting as a Tele-Radiology Order Fulfiller).

The Tele-radiology Service (acting as a Tele-Radiology Order Fulfiller) receives the canceled order and changes the status of the “interpretation work list” to Canceled. How this is accomplished is outside the scope of this Use Case and is a proprietary implementation specific.

Note: When a radiologist from the tele-radiology service accepts the order from the “interpretation work list” (i.e. the radiologist is ready to read the study) the status of “in progress” is sent by the Tele-Radiology Service and received by the hospital RIS/PACS. Therefore, it would be too late for the local radiologist to cancel the order and it would be best to let the remote service interpret the imaging study. The status stays in the “in progress” state until the interpretation has been “completed” or “Aborted”. This is not shown but a possible exception case.

Only one typical example is provided, but similar information workflow could occur.

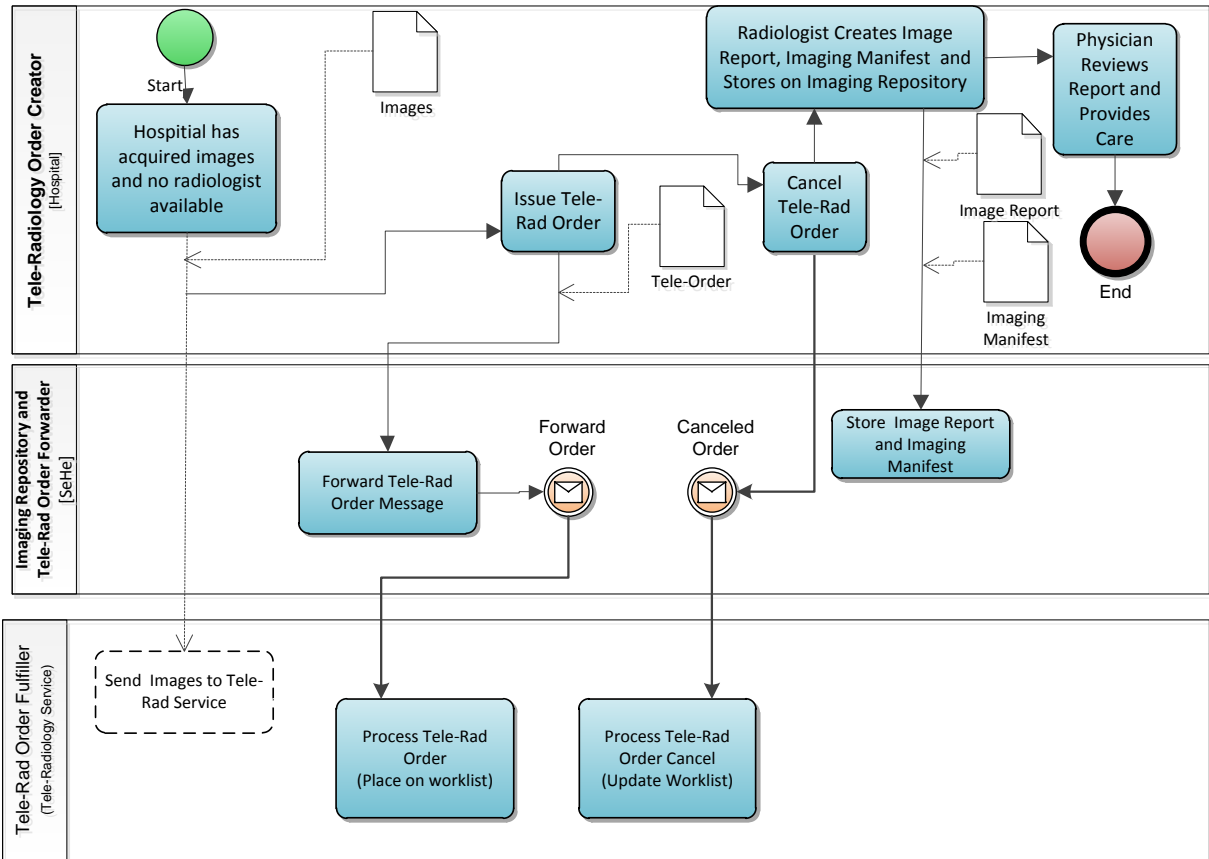

Figure 1.3-2 Tele-Radiology Cancel Order

2.6 Specific Workflow Scenarios

The following sections provide a state diagram of tele-radiology order transition states and short descriptions of scenarios that complement the Use Case flow of events by using the defined transactions in specific ways. Some of these scenarios highlight variants to the Use Case main flow of events while others describe interactions with local workflow situations that are beyond the scope of the Use Case but consistent with it. These workflow scenarios are not intended to be an exhaustive list.

2.6.1 Tele-Radiology Order Transition State Diagram

Figure 1.3-3 Tele-Radiology Order Transition State Diagram

depicts the transition states and the possible transitions which exist for a tele-radiology order. They are based upon the scenarios described below.

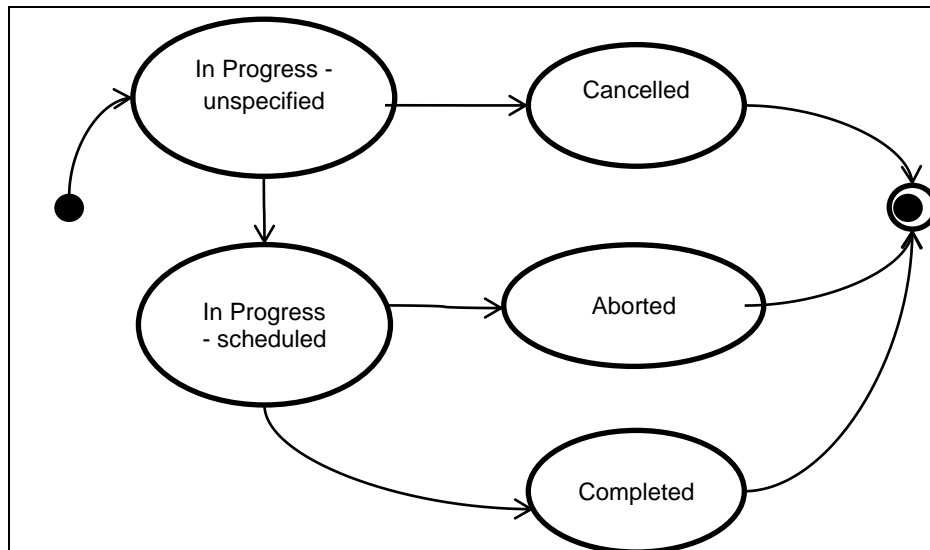

Figure 1.3-3 Tele-Radiology Order Transition State Diagram

2.6.2 Scenario 1: Tele-radiology service processes a successful order

A Tele-radiology Order Creator issues a tele-radiology order which references the imaging study that was already acquired for a patient. When the order is selected on the tele-radiology service, the Tele-radiology Order Fulfiller sends an order message with an updated status set to “In Progress”. This allows the Order Creator to let its users know that the order issued to the Tele-radiology Service is being processed by a radiologist.

The radiologist performs the requested imaging interpretation and the radiology report and interpreted images are stored to the SeHE Document Repository by the tele-radiology service. The Tele-radiology Order Fulfiller sends an order message with the order status set to “completed”. At this time, the imaging report is available and may be retrieved, reviewed and used to deliver patient care.

2.6.3 Scenario 2: A Tele-Radiology Order Is Cancelled Before It Has Been Processed By the Tele-Radiology Service

A tele-radiology order message was previously created and received by the tele-radiology service, but yet to be selected for processing (i.e., the order is waiting to be accepted by a radiologist within the tele-radiology service). A hospital radiologist becomes available at the ordering facility. The Tele-radiology Order Creator sends an order message with the status of “cancelled”. The tele-radiology service cancels the order and does not perform the interpretation. The radiologist at the local hospital interprets the imaging study and creates a report. The report is stored on the SeHE Document Repository.

2.6.4 Scenario 3: A Tele-Radiology Order Is Processed By the Tele-Radiology Service and Is Aborted

The tele-radiology service receives an order message that a tele-radiology order has been created for a patient (as described in previous scenarios). When the order is selected on the tele-

radiology service the Tele-radiology Order Fulfiller sends an order message with an updated status set to “In Progress”.

The radiologist on the tele-radiology service reviews the requested imaging study and determines the images are not sufficient to perform the interpretation. The Tele-radiology Order Fulfiller updates the order status to “aborted”.

2.6.5 Scenario 4: A Tele-Radiology Order Is Cancelled but It Has Already Been Processed By the Tele-Radiology Service

There is a rare condition that exists where a radiologist is attempting to cancel an order after the processing has already been started by the tele-radiology service. When the order is selected on the tele-radiology service the Tele-radiology Order Fulfiller sends an order message with an updated status set to “In Progress”. Before the Tele-radiology Order Creator receives the order message with the status of “In Progress”, it had initiated an order message to “cancel” the order. When the Tele-radiology Order Creator receives the status message of “In Progress” it knows the “cancel” has been received after the “in progress” was sent and the “cancel” has not been accepted. Since the tele-radiology service has already selected the order, the radiologist performs the interpretation and generates the imaging report.

2.7 Service Model

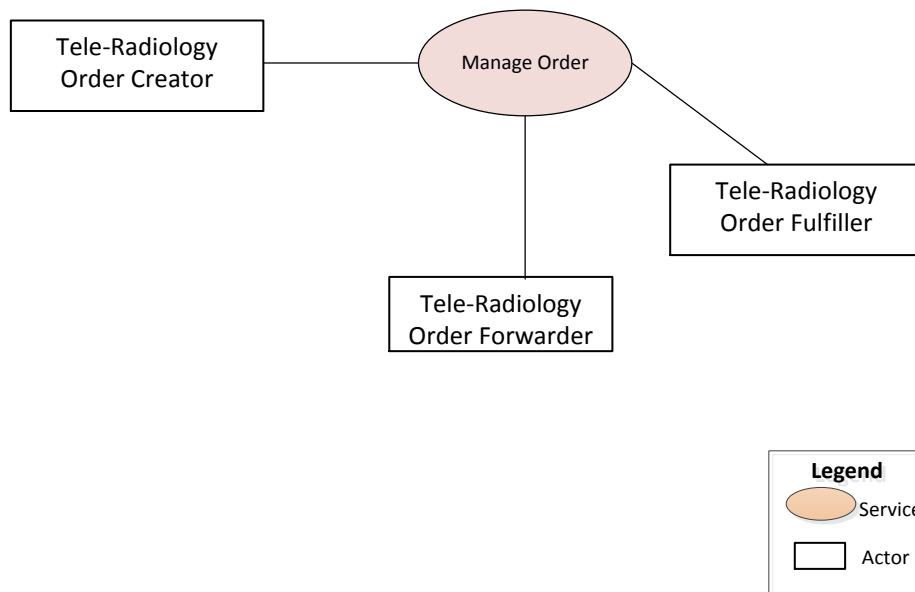

Figure 1.3-4 Tele-Radiology Order Service Model

2.8 Service Description

The Services defined in this Use Case are described in Table 1.3-2 Services

Table 1.3-2 Services

SERVICE NAME	DESCRIPTION
Manage Order	Manage Order is used to create and manage the tele-radiology order along with its status change (cancel, in-progress, completed, aborted).

2.9 Pre-Conditions

Table 1.3-3 Pre-Conditions

identifies pre-conditions for this Use Case.

Table 1.3-3 Pre-Conditions

ACTOR NAME	SERVICES	DESCRIPTION
All Actors	All Services	It is expected that all services initiated or provided by this actor operate in accordance to the Saudi eHealth Interoperability Polices and Interoperability Specifications.
Tele-Radiology Order Creator	Manage Order	An authorized provider and/or organization determines that an imaging study locally acquired needs to be interpreted for a patient.
		The workflow for performing the image acquisition is outside the scope of this Use Case. The way the Tele-Radiology Order Creator is integrated with a local or national RIS/PACS workflow is outside the scope of this Use Case (integrating RIS/PACS with imaging modalities is a common and well known workflow process).
Tele-Radiology Order Fulfiller	Manage Order	Is authorized by the KSA to perform tele-radiology services.

2.10 Post-Conditions

Table 1.3-4 post Conditions

identifies post-conditions for this Use Case.

Table 1.3-4 post Conditions

ACTOR NAME	SERVICES	DESCRIPTION
Tele-Radiology Order Fulfiller	Manage Order	A patient's tele-radiology order has been processed (i.e. completed, aborted, or canceled).

2.11 Data Requirements

This section defines the general scope of the type of data needed for this Use Case. However, it does not define the entire detailed data set as this will be discussed in the Saudi eHealth Interoperability Specification design document.

2.11.1 Tele-Radiology Order Data

A healthcare provider creates and transmits a coded tele-radiology order through the SeHE System (which includes the Tele-Radiology Order Forwarder) for requesting tele-radiology reading services for a locally acquired study that has already been shared in the Imaging Repository.

The information content of an imaging order includes basic demographic information of the patient throughout the SeHE network. Table 1.3-5 Tele-radiology Order Data Content provides a minimum set of information content.

Table 1.3-5 Tele-radiology Order Data Content

TELE-RADIOLOGY DATA	DESCRIPTION	TEXT/CODED
Source and Context information about the Tele-radiology Order	Includes data such as: <ul style="list-style-type: none"> • Patient demographics, such as Health ID, patient name, birth date, gender. • Physician/organization that ordered the tele-radiology procedure, such as ordering provider, organization name, order call back number. • Local imaging order Id. • Other 	Text and Coded
Tele-radiology Order Information	This includes data such as: order priority, KSA-Wide accession number, modality, reason for study, relevant clinical information, prior studies exist, technician acquisition notes, etc.	Text and Coded

2.12 Assumptions and Dependencies

Table 1.3-6 Use Case Dependencies

identifies and describes Use Cases which this Use Case depends upon information workflow.

Table 1.3-6 Use Case Dependencies

USE CASE NAME	DEPENDENCY ASSUMPTIONS
KSA-Wide Patient Demographic Query	The KSA-Wide Patient Demographic Query Use Case is used to obtain Health ID and demographic information for the patient for whom the Tele-Radiology Order is being requested. It is used to ensure that the nationwide Health ID is used to register image manifests and reports for the correct patient. It provides consistent data into the imaging information.

Sharing Images and Imaging Reports	The Sharing Images and Imaging Reports Use Case is used to create and store the images acquired and to be interpreted in responding to the tele-radiology order as well as the imaging report resulting from this tele-radiology order. It also is used to pull prior related images and imaging reports for review.
------------------------------------	--

2.13 Special Requirements

N/A

2.14 Notes and Issues

N/A